

Model: DHM-800Z

Ultrasonic Electronic Height and Weight Body Scale



USER MANUAL

Installation and Adjustment

THANKS FOR USING OUR HEALTHCARE PRODUCTS

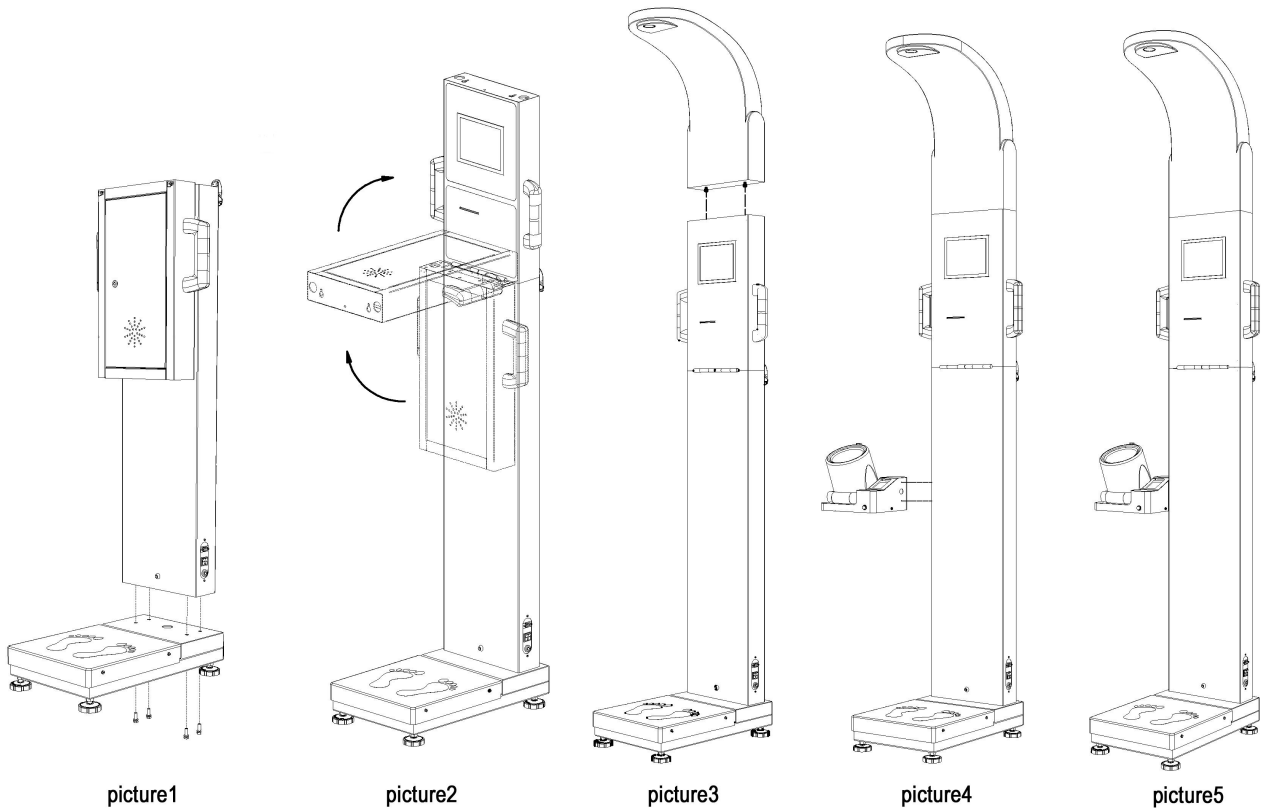

Installation Instruction:

- 1、 Open packing cartons and check all accessories :
Basement, Body machine (upper and lower body machine are connected by hinge), Blood pressure machine, Plastic foot, Instruction, and other accessories.
- 2、 As shown in picture 1, connect the machine with basement by M8 bolt, then plug and screw aviation plug of weight sensor into lower body machine (as shown in step 1).
- 3、 As shown in picture 2, turn the upper body machine into vertical position and fasten the lock catch between upper and lower body machine.
- 4、 As shown in picture 3, Connect the height accessories with upper body machine by fasten M5 screw and insert the plug of height probe into main board.
- 5、 If there is blood pressure machine , connect the blood pressure machine with lower machine(as shown in picture 4) and fasten 2 M4 screws from inside of the body machine. Then insert the cable and plug in to mainboard.

step1

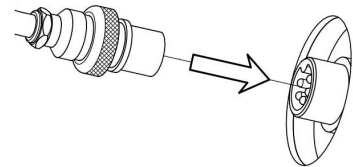

step2

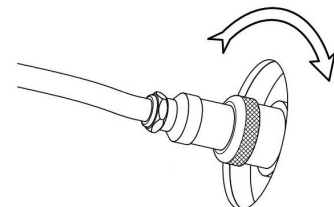

Conventional Diagram Of Mother Board:

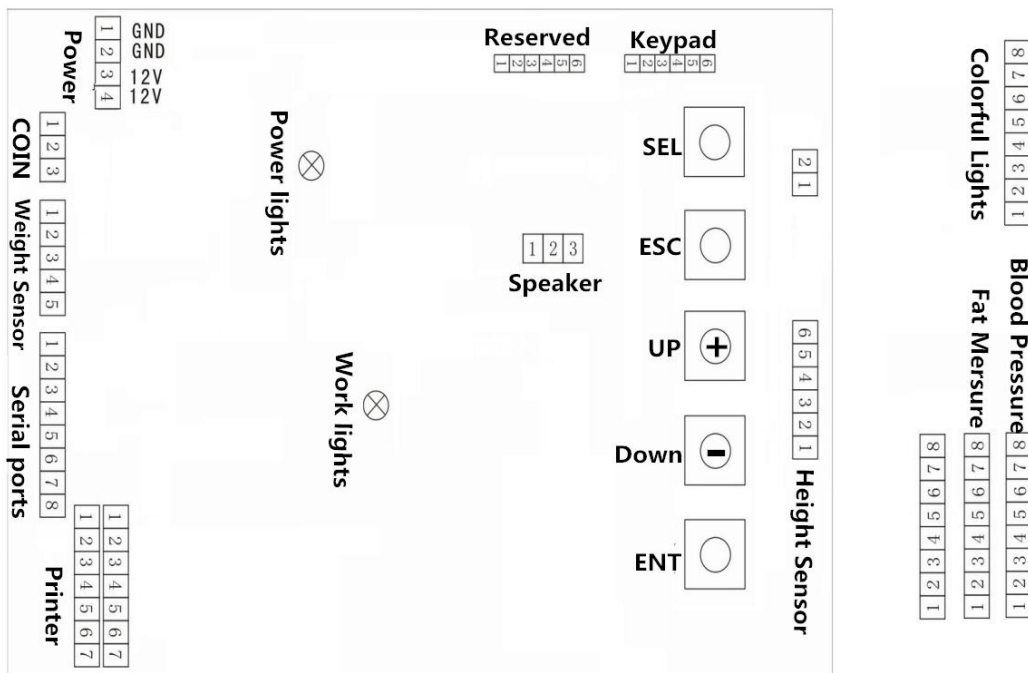

Operation: Turn on: connect the power supply wire, turn on the machine, the screen would show you initializing information (the state of display module, height measurement module, blood pressure module, fat module, print module and weight measurement module etc.). **Attention:** please make sure the voltage of power supply is DC 12V, and there should be nothing heavy on the platform.

Measurement: Enter the coin(s). After entering the coin(s), the machine will come into measurement state. If there is someone on the platform, the machine will automatically start to measure the person’s height and weight. After measured height and weight there will have voice broadcast to tell you the next step. Follow the screen and voice prompts to measure blood pressure and fat, and finally print the measurement results.

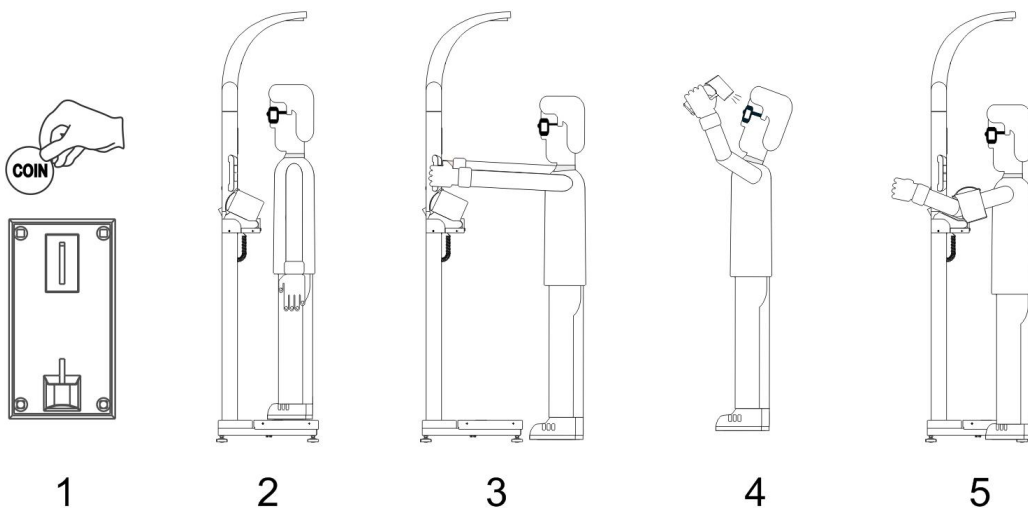

The Measurement Procedures and Matters Need Attention:

Step one: Enter the coin(s). After entering the coin(s), the machine will come into measurement state. Please choose your gender(sex), the machine will automatically start to measure the person's height and weight.

Step two: Measure height and weight. As the picture shows, the person is supposed to stand stably and keep the body straight, and do not look around or shake the body, all of these are intended to get a faster and more accurate result.

Step three: Measure the Fat rate and Fat mass. After the height and weight measurement is finished, press the "NEXT" button, then it will display measure Fat Screen, click on the age input box, enter your age, hold the fat meter with both hands, arm straight, when you are ready , Click on the "Start" button and start measure fat. **Note:** If the machine does not have the function of measure Fat, please directly into the fifth step.

Step four: Measure Blood pressure and Pulse: Body Fat ends. Please press the "Next", then put the arm (suggest right arm) into the blood pressure monitor, and press the "START" it will measure your blood pressure. Blood pressure measurement takes some time, when you are measuring blood pressure please relax, do not move nor speak, otherwise it will cause measurement error or even measurement failure. If the measurement fails, you can press the blood pressure measurement button again to make another measurement. When the measurement result is displayed, the entire measurement is finished. **Note:** If the machine does not have the function of measure blood pressure, please directly into the next step.

Step five: Print measurement result. Click the "Next" button to print measurement result.

Function setting and adjustment:

All functions are set and adjusted by keys on the main board(+ - SEL ENT ESC). Please look at the diagram of the main board.

When the machine in the free state (not measure and not menu adjustment), press "ENT" button, the screen of machine will displays a menu item (as picture):



Date adjustment:



Press  into the state of adjustment.

Write down Date and Time into (Input Box).

Press **Enter** to save the adjustment results and exit.

Press **Cancel** do not save the adjustment results and exit.



Weight adjustment:



Press  into the state of adjustment.

Please follow the instruction of display to adjust weight.

Press **Enter** to save the adjustment results and exit.

Press **Cancel** do not save the adjustment results and exit.

After finished adjustment, observe the correction value, if the value reach the range limit, the machine may be faulty.



Height adjustment:



Press  into the state of adjustment.

Please follow the instruction of display to adjust Height.

Press  to save the adjustment results and exit.

Press  do not save the adjustment results and exit.

After finished adjustment, observe the correction value, if the value reach the range limit, the machine may be faulty.

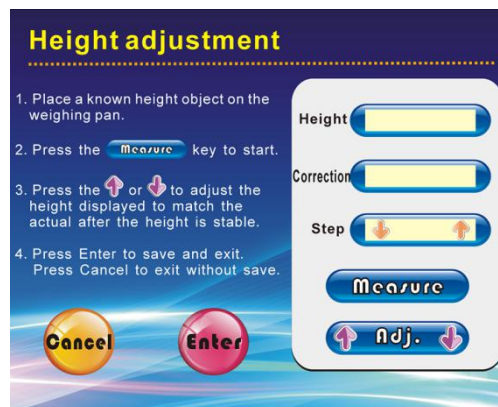

Body mass index (BMI) adjustment:



Press  into the state of adjustment.

Write down BMI Value e into(Input Box).

Press  to save the adjustment results and exit.

Press  do not save the adjustment results and exit.

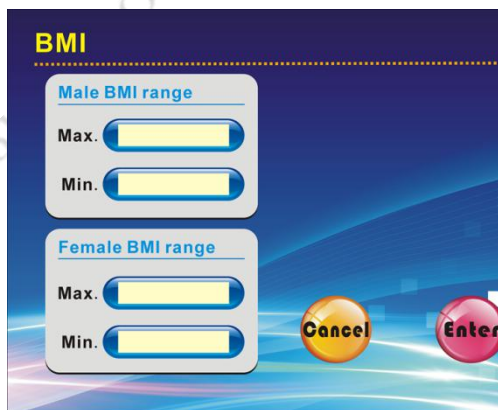



Print adjustment:



Press  into the state of adjustment.

Press the print result you want.

Press  to save the adjustment results and exit.

Press  do not save the adjustment results and exit.

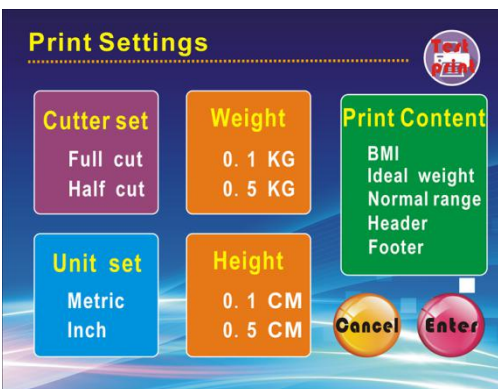



Voice adjustment:



Press  into the state of adjustment.

Click on the input box adjust voice or picture cycle interval.

Press  to save the adjustment results and exit.

Press  do not save the adjustment results and exit.

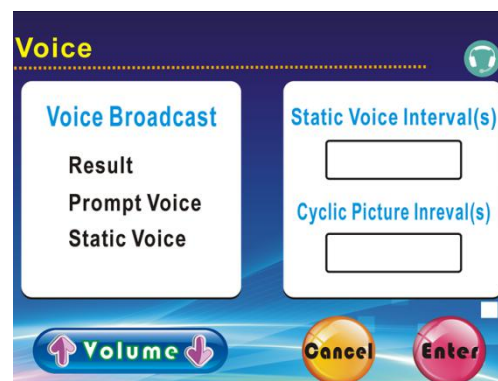

Coin setting:



Press  into the state of adjustment.

White down coin value to the input box.

Select the right coin currency symbol.

Press Enter to save the adjustment results and exit.

Press Cancel do not save the adjustment results and exit.

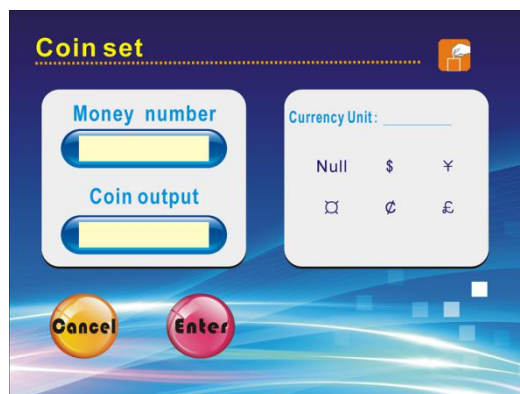

Check the total number of measurement:



Press  into the state of adjustment.

Press “Clear” button to remove the measurement count.

Press “Print” button to print the measurement count.

Press Enter to save the adjustment results and exit.

Press Cancel do not save the adjustment results and exit.

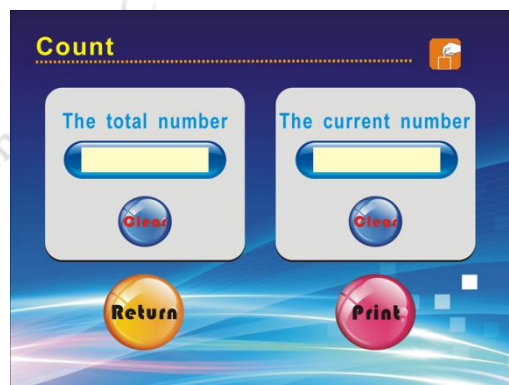

Language setting:



Press  into the state of adjustment.

Select the Language you need.

Press Enter to save the adjustment results and exit.

Press Cancel do not save the adjustment results and exit.



Restore factory setting:



Press  into the state of adjustment.

Press Enter to save the adjustment results and exit.

Press Cancel do not save the adjustment results and exit.

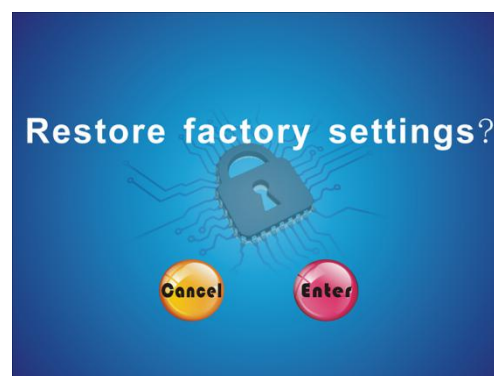

Measurement interval setting:

Press  into the state of adjustment.

Write the time into “input box”

Press to save the adjustment results and exit.

Press do not save the adjustment results and exit.

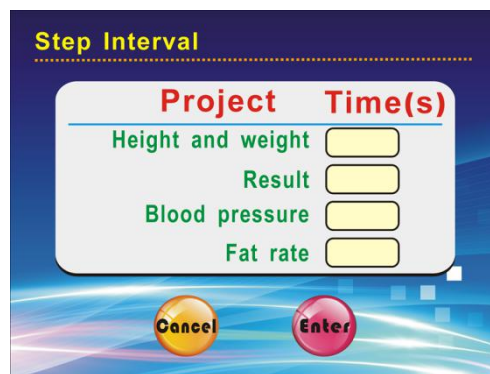
**About our Factory:**

Press  to see our factory

After watching our company's information and clicking anywhere to return to the main menu.

Technical Parameters:

Weight measurement range: 3-500kg

Weight minimum division: ± 0.1 kg

Height measurement range: 80-200cm

Height minimum division: ± 0.5 cm

Power source: DC 10-14V Power: 60 W

Products size: 49x34x235cm

Products weight: 45KG